

A-A (1 : 12)

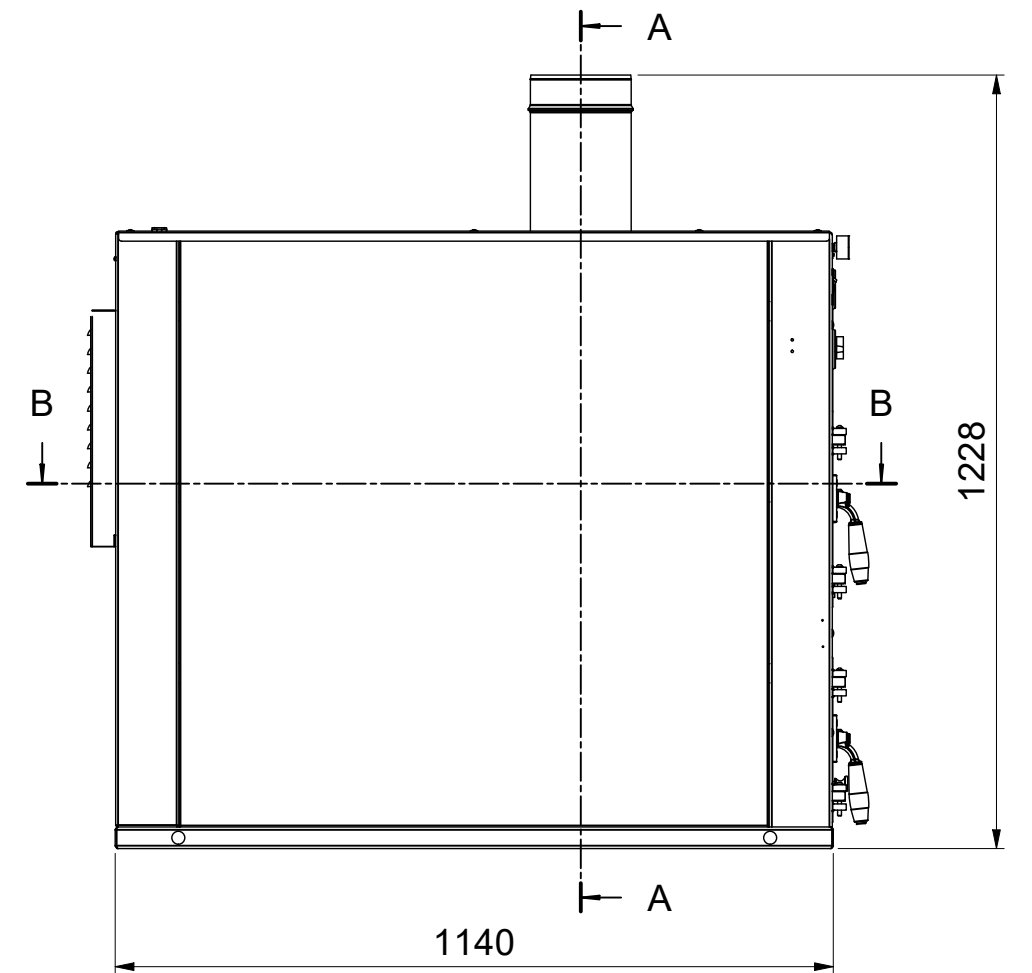

B-B (1 : 12)

COIBENTAZIONE pannello rigido 70mm 70 kg / m³

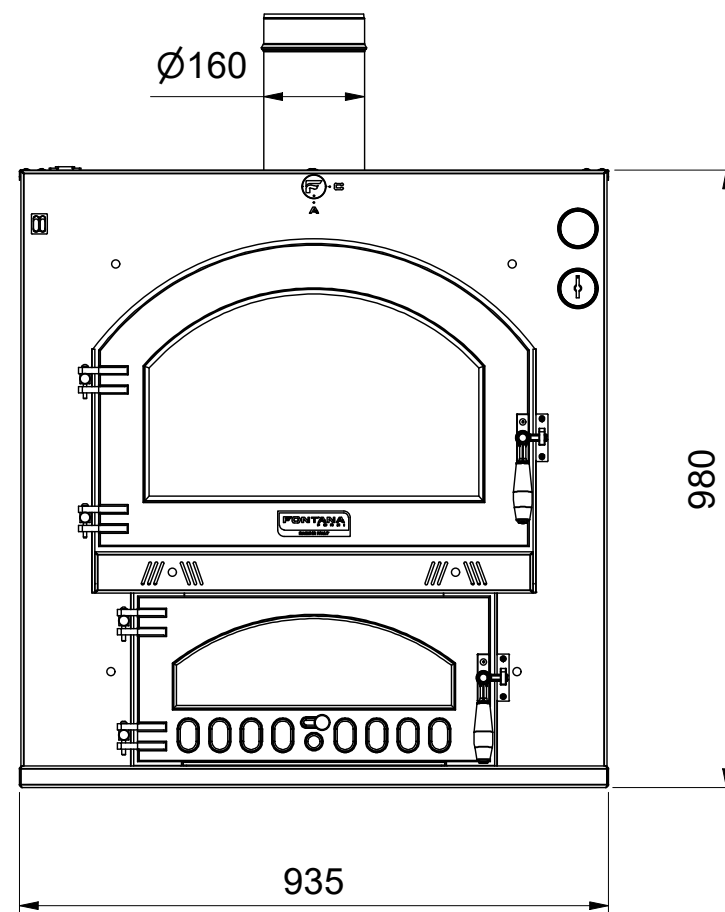
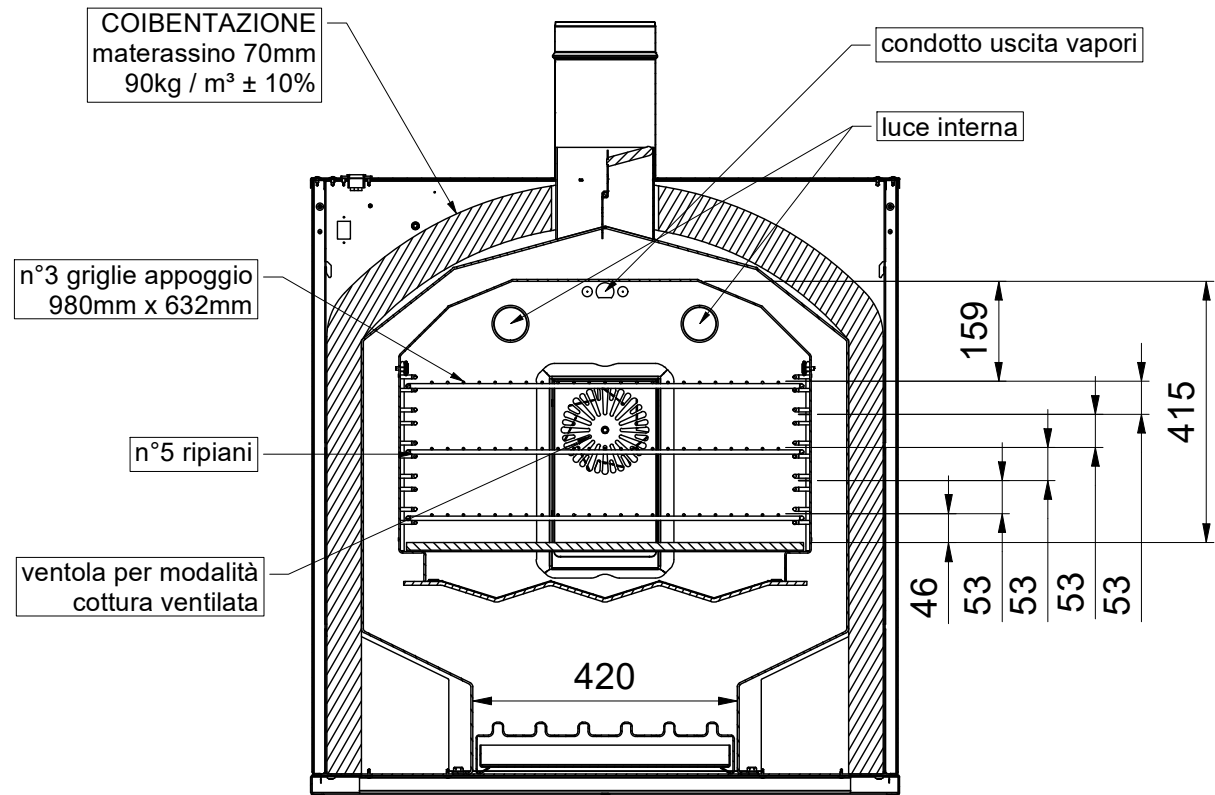
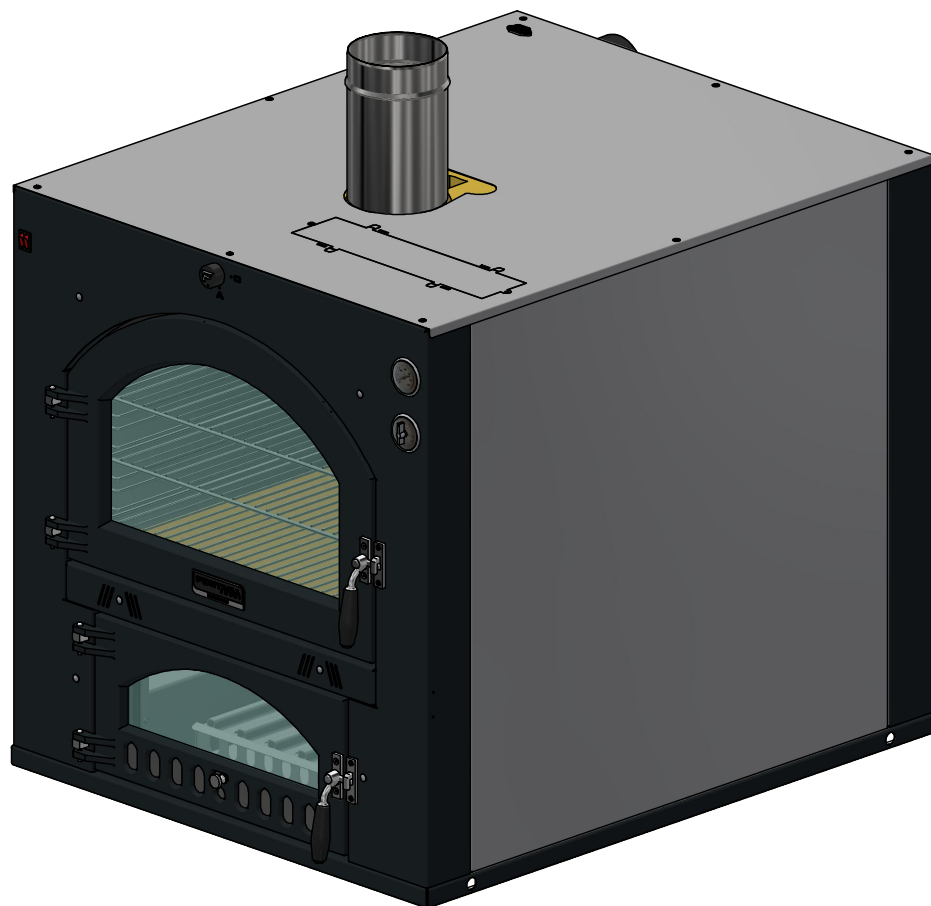
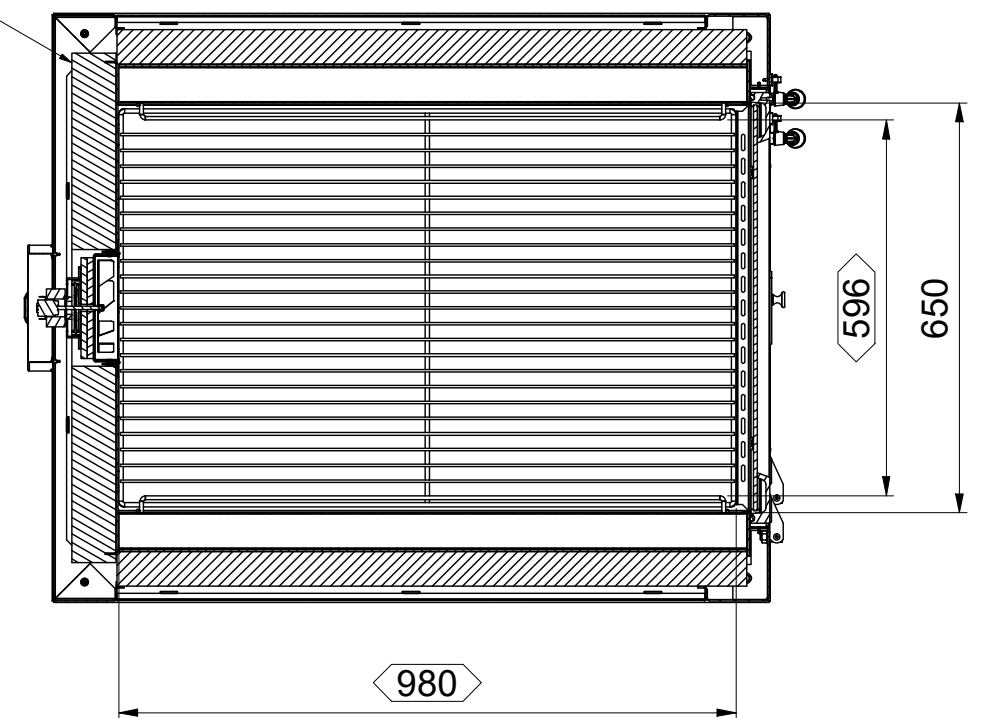
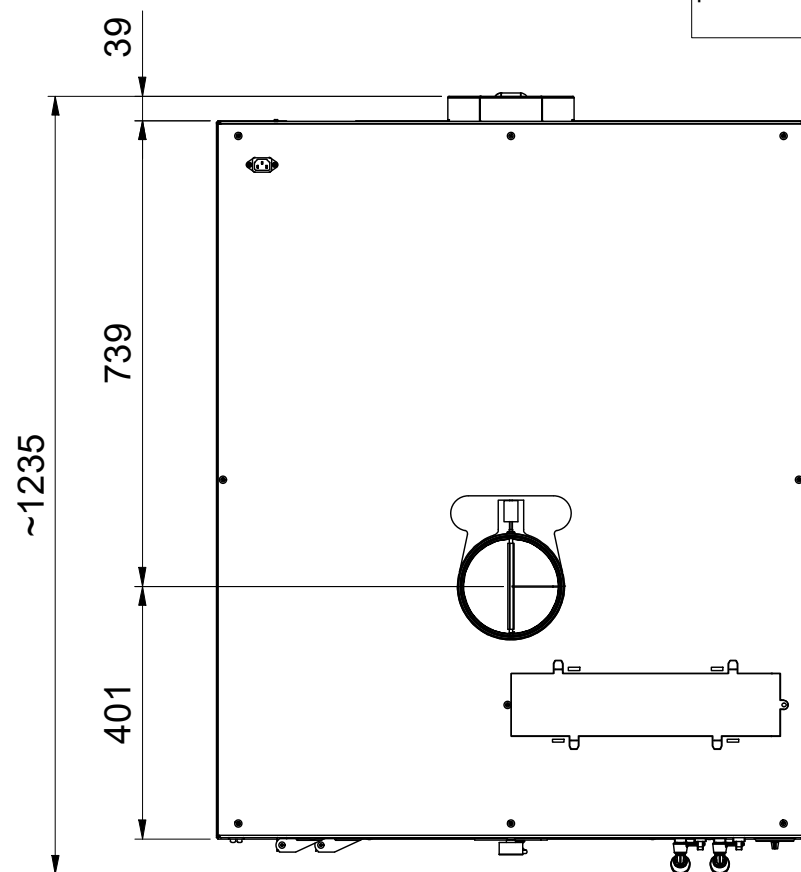

Note generali	Tipo di cava consigliato	Rugosità	Disegn. Bottacchiari A.
			Data 27/10/2023
Materiale		Finitura	Colore
Tolleranze generali	NORMA EUROPEA EN 22768-1 m (PRECISIONE MEDIA) DIMENSIONI ANGOLARI EN 22768-1 m (MEDIA)		Scala 1 : 12
			Peso 345 Kg
FONTANA Via G. di Vittorio, 6/8 San Lorenzo in Campo (PU) - ITALY Tel. 0721.776697 Fax 0721.735370		La ditta FONTANA FORNI S.r.l. si riserva la proprietà e il diritto esclusivo del progetto, che pertanto non può essere né riprodotto né comunicato a terzi senza esplicito permesso da parte nostra.	Modello 100x65 (INC QV) »2023 Denominazione FORNO mod. 100x65 INC QV »2023 Dis. N° 100x65 (INC QV) »2023 Rev.00